

Geometry

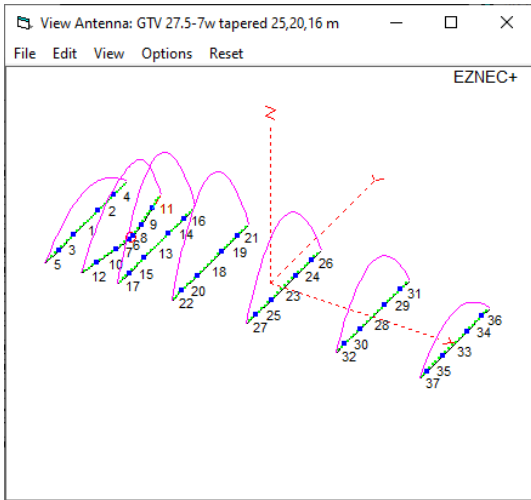

Pos.	Length	Rest per side
0	5362	881
1689	5194	797
2643	5070	735
4641	5000	700
7404	4886	643
10752	4814	607
13823	4560	480

Taper scheme

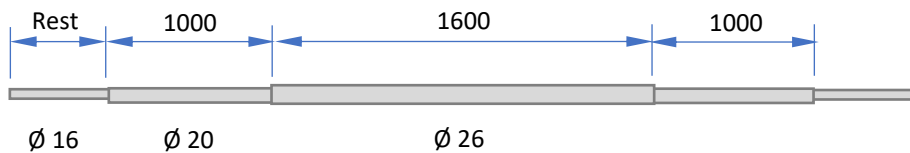

Bent Dipole: same taper, wire 6 only for simulation, wire 7, 8 (Ø 25) in V-shape mounted on a plate.

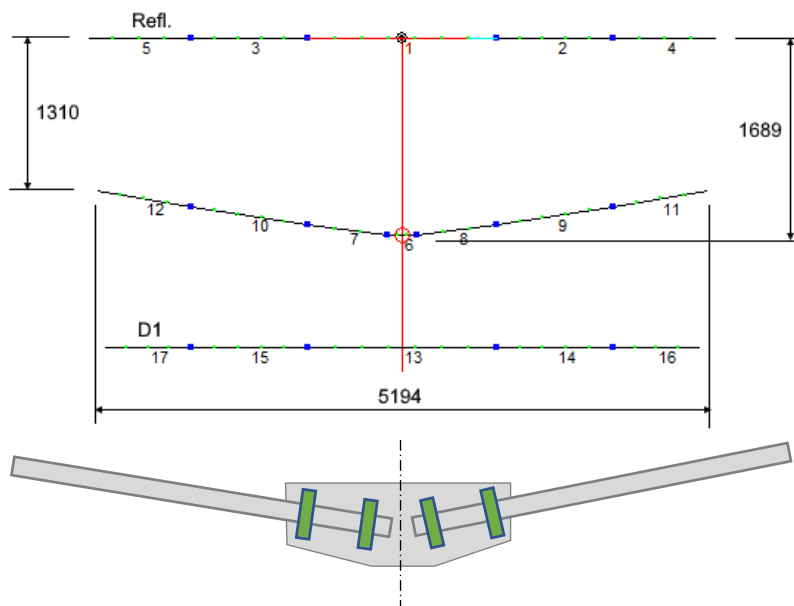

Free Space

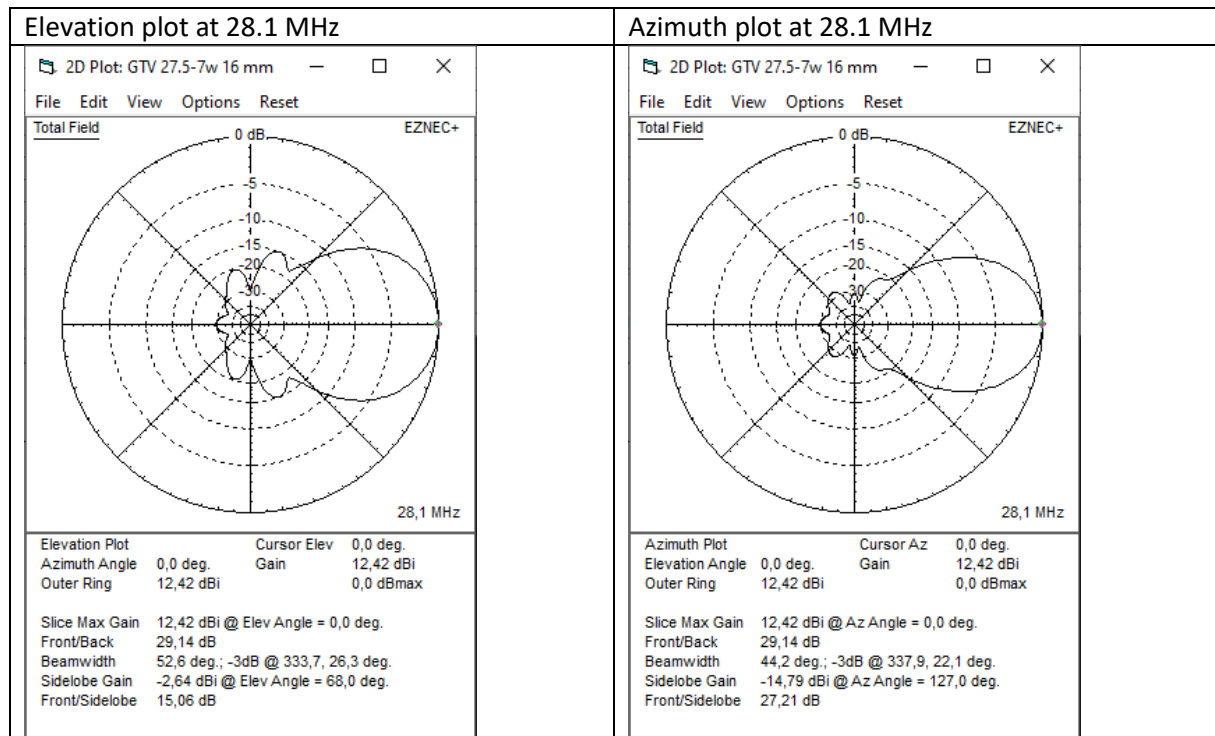
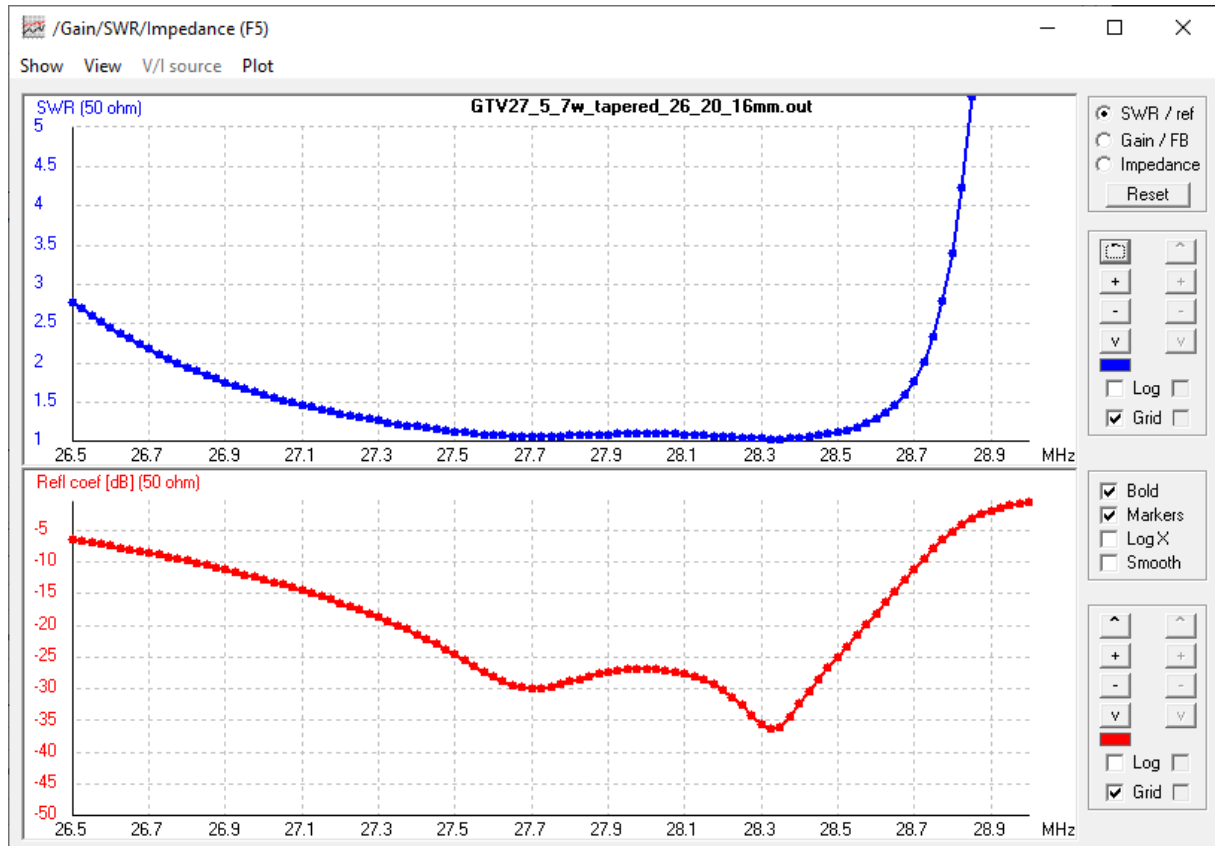

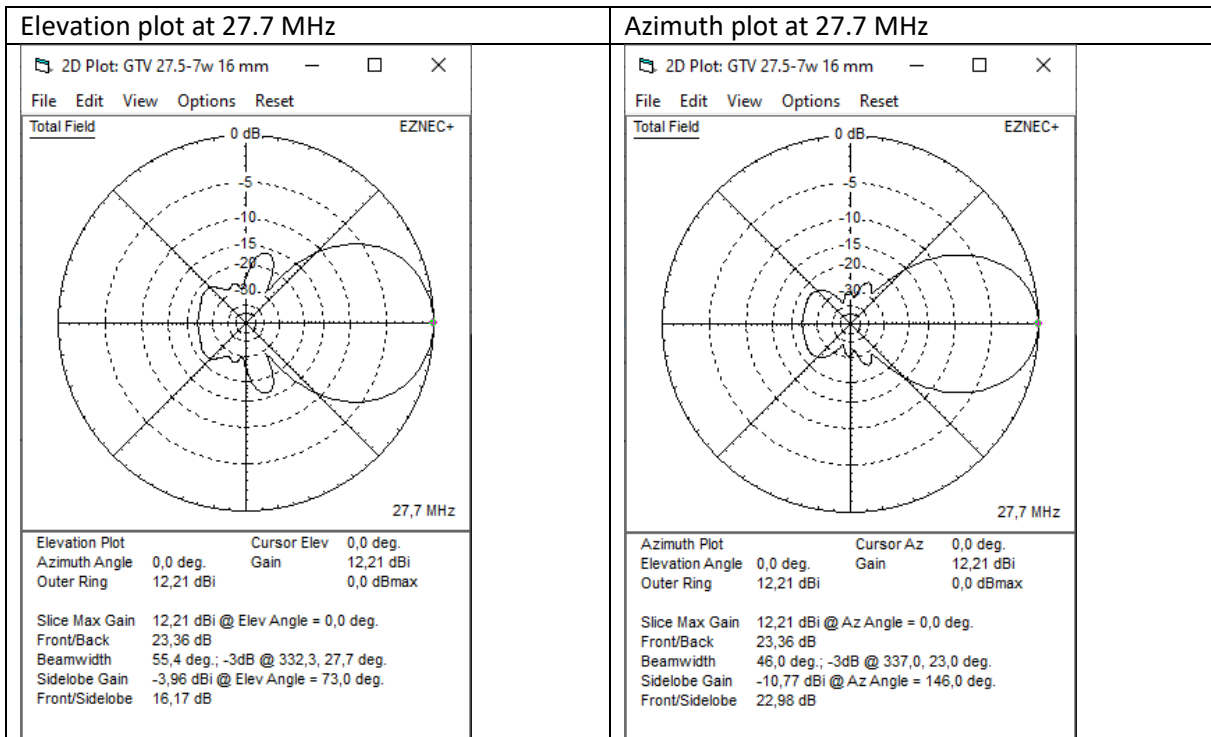
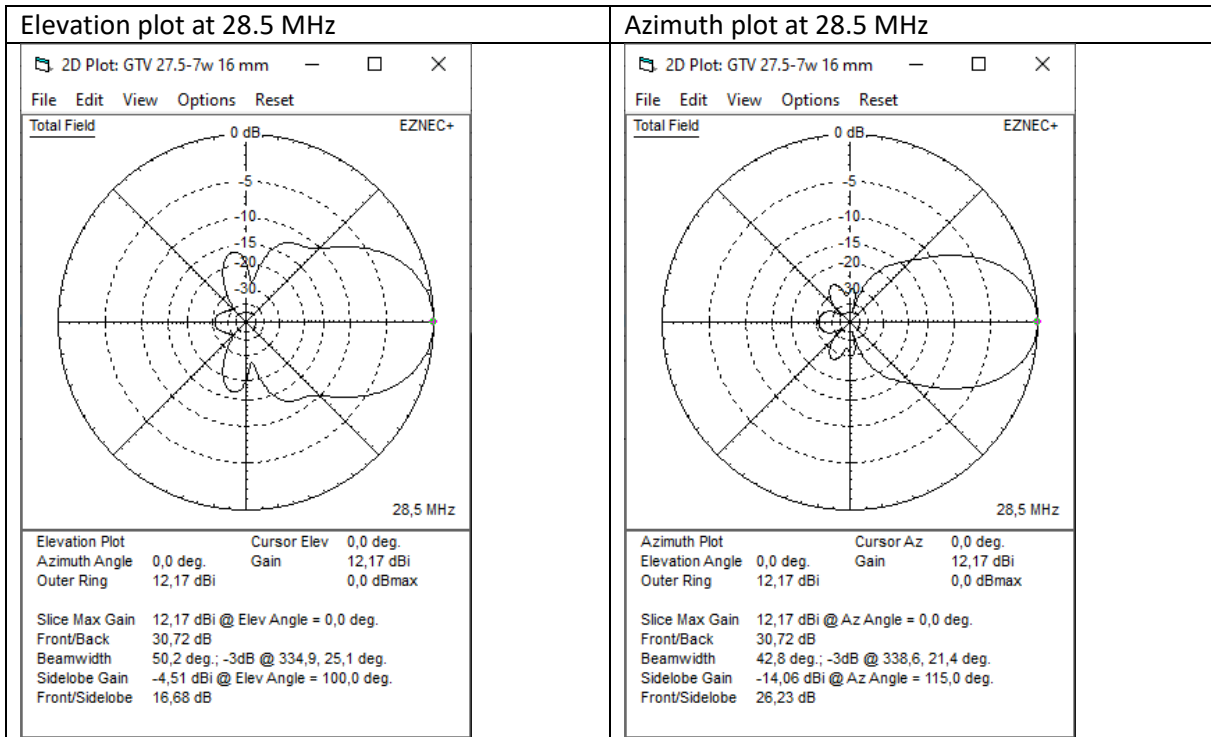

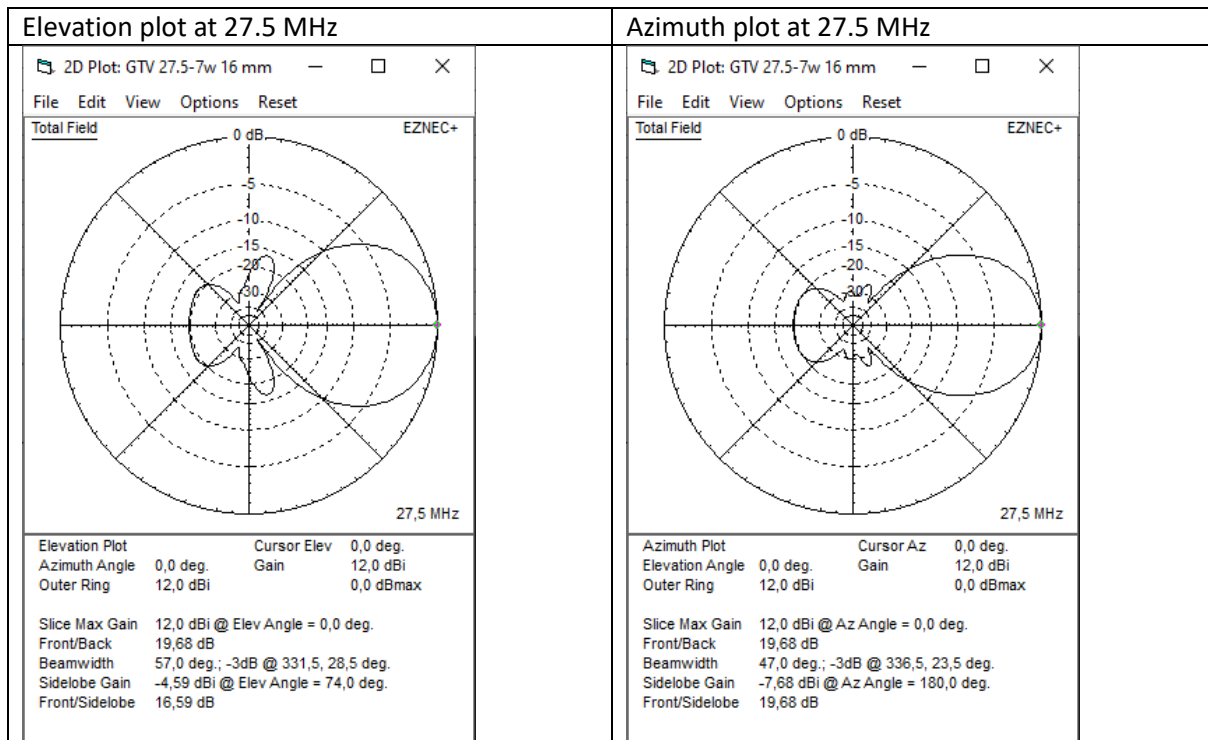

At 18.0 m above ,perfect ground'

